

## GENERAL INFORMATION

**Project Name:** \_\_\_\_\_  
**Item:** \_\_\_\_\_  
**Quantity:** \_\_\_\_\_  
**Model:** ZG9500-4  
**Length:** \_\_\_\_\_

## STANDARD NSF LISTED FINISH OPTIONS

- |                                           |                                                |
|-------------------------------------------|------------------------------------------------|
| <input type="checkbox"/> Brushed Aluminum | <input type="checkbox"/> Chrome                |
| <input type="checkbox"/> Gloss Black      | <input type="checkbox"/> Wrinkle Black         |
| <input type="checkbox"/> Smoked Copper    | <input type="checkbox"/> Polished Brass Finish |
| <input type="checkbox"/> Other _____      |                                                |

## GLASS THICKNESS

- |                                                                                                      |
|------------------------------------------------------------------------------------------------------|
| <input type="checkbox"/> 1/4" Tempered Glass (not for shelves)<br>Centerline Max 54"                 |
| <input type="checkbox"/> 3/8" Tempered Glass (for shelf or span more than 54")<br>Centerline Max 66" |

## GLASS CORNERS

- |                                                      |                                         |
|------------------------------------------------------|-----------------------------------------|
| <input type="checkbox"/> 1" Radius Corner (standard) | <input type="checkbox"/> Square Corners |
|------------------------------------------------------|-----------------------------------------|

## INSTALLATION OPTIONS

**Above-Counter:** Stainless Steel Counter  
**Under-Counter:** Stainless Steel Counter  
 (Requires Under-Counter Reinforcement & Access)

**Above-Counter:** Millwork Counter

**Under-Counter:** Millwork Counter

**See Installation Page for More Details.**

- |                                                                                              |
|----------------------------------------------------------------------------------------------|
| <input type="checkbox"/> SS1: EZ Mount 2" x 8" Flange                                        |
| <input type="checkbox"/> SSU3-H: Heavy-Duty Flange                                           |
| <input type="checkbox"/> SSU3-N: Narrow Flange                                               |
| <input type="checkbox"/> SSU5-H: Heavy-Duty Flange                                           |
| <input type="checkbox"/> SSU5-N: Narrow Flange                                               |
| <input type="checkbox"/> MW1: Heavy-Duty Flange                                              |
| <input type="checkbox"/> MW2: Narrow Flange                                                  |
| <input type="checkbox"/> MWU3: Narrow Flange                                                 |
| <input type="checkbox"/> MWU4: Compression Installation (not recommended for solid surfaces) |
| <input type="checkbox"/> MWU5: Heavy-Duty Flange                                             |

## ZG9500-4

*Operator-Serve and/or Partition*

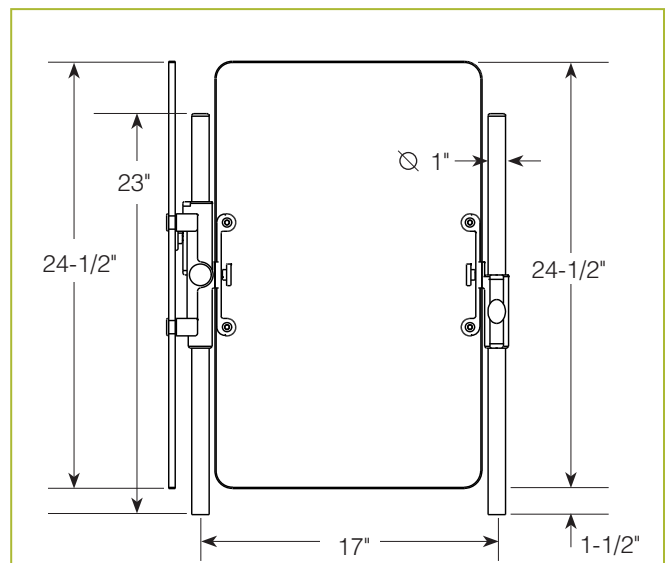

To meet NSF guidelines, end panels are included on all BSI quotations unless specifically excluded. (See End Panel Page for More Details.)

## \* Approval Drawings Required